

Series S2000

Low-Cost Differential Pressure Gauge



Features

- Mounts in Industry Standard Holes
- Accuracy 2%
- Die Cast Aluminum Housing

Applications

- Filter Status
- Duct Static Pressure
- Clean Room Pressure
- Building Pressure
- Fan and Blower Pressure
- Paint Booths
- Dust Collectors
- Glove Box Pressure
- Bubbler Systems
- Cabinet Purging

The Series S2000 is a low cost, diaphragm operated, differential pressure gauge. The S2000 can be used in applications for measuring positive, negative, or differential pressure with an accuracy of 2%. Standard applications include monitoring filter status, duct static pressure, room pressure, fan or blower pressure, paint booths, dust collectors, and cabinet purging along with many others.

SPECIFICATIONS

Pressure Limits: -20" Hg to 15 PSI (-0.677 bar to 1.034 bar);
MP option: 35 PSI (2.41 bar); HP option:
80 PSI (5.52 bar)

Media compatibility: Air and compatible gasses

Accuracy: +/- 2% full scale (+/- 3% on -0 and +/- 4% on -00)
throughout range at 70°F (21°C)

Temperature Ranges: 20° to 140°F (-7° to 60°C)

Housing Material: Die cast aluminum case and bezel, with
acrylic cover

Process Connection: 1/8" female NPT duplicate high and low
pressure taps – one pair side and one
pair back.

Weight: 1 lb 2 oz (510 g), MP & HP 2 lb 2 oz (963 g)

Accessories: Two 1/8" NPT barbed fittings, two 1/8" NPT
plugs, and three mounting tabs and screws.

DIMENSIONAL DRAWINGS

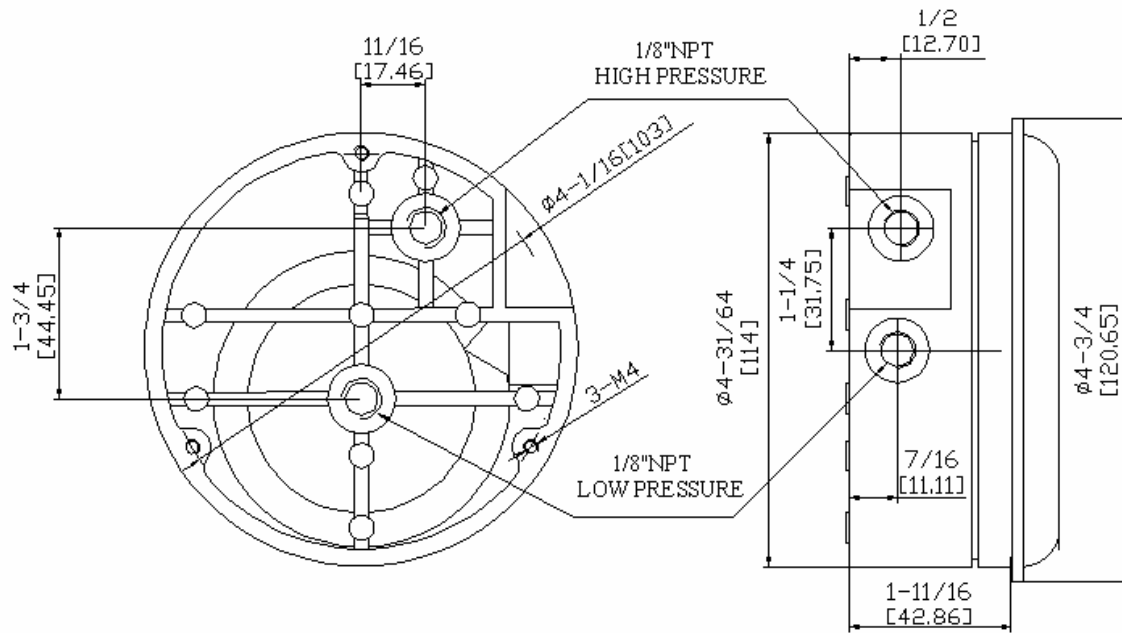

ORDERING INFORMATION

Model Number	Pressure Range	Model Number	Pressure Range
S2000-00	0 - 0.25"	S2025	0 - 25"
S2000-0	0 - 0.5"	S2030	0 - 30"
S2001	0 - 1"	S2050	0 - 50"
S2002	0 - 2"	S2100	0 - 100"
S2003	0 - 3"		
S2004	0 - 4"		
S2005	0 - 5"	S2300-0	0.25 - 0 - 0.25"
S2006	0 - 6"	S2301	0.5 - 0 - 0.5"
S2008	0 - 8"	S2302	1 - 0 - 1"
S2010	0 - 10"	S2304	2 - 0 - 2"
S2015	0 - 15"	S2310	5 - 0 - 5"
S2020	0 - 20"	S2320	10 - 0 - 10"

Sensocon, Inc.
 Phone: (863) 248-2800
 Fax: (863) 248-2798

www.sensocon.com

A1xxx-xx



OTHER PRODUCTS

The Series A Family of products offers an alternative to the S2000 when better accuracy, a better look or more features are desired. The Series A Family is also available with a 4-20 mA output and the A3 and A4 include 2 8A SPDT relays and an associated software package that allows full configuration of variables such as setpoints, dead band, engineering units and more. The A3 and A4 are also capable of reading out directly in velocity or flow.

A4xxx-xx

